

ZS+ 标准气缸, 带宽活塞杆头

ZK+ 标准短缸, 带宽活塞杆头

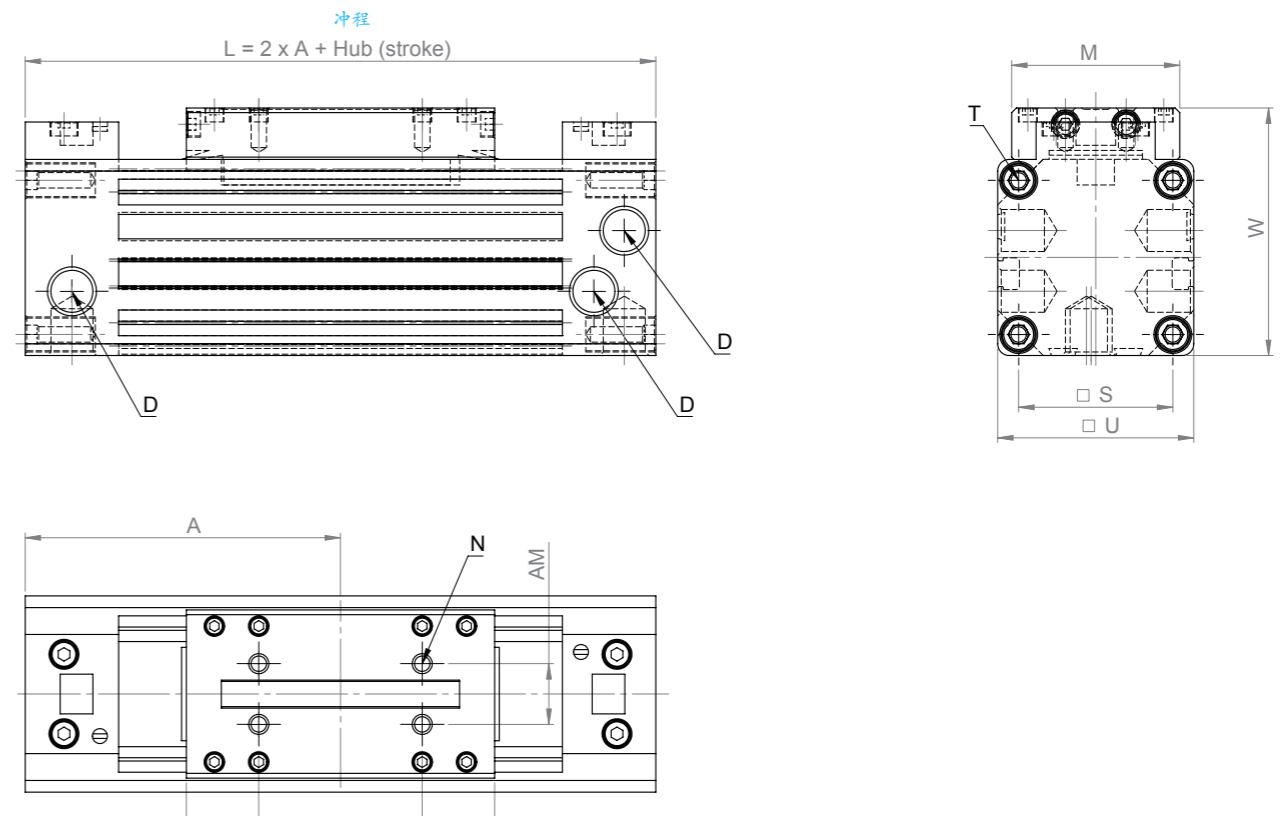
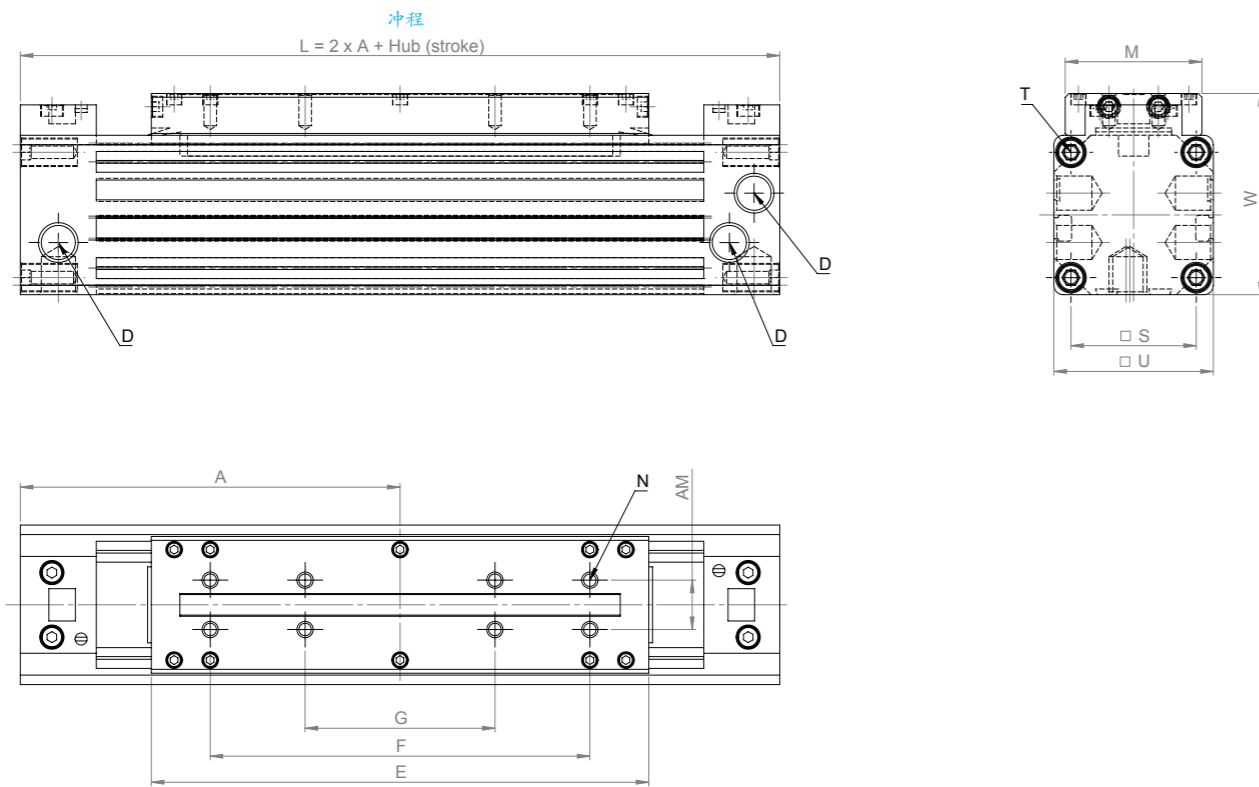

Measurements table

测量值表

Piston-Ø 活塞-Ø	Ø 18 mm	Ø 25 mm	Ø 32 mm	Ø 40 mm	Ø 50 mm	Ø 63 mm
A		100		150		
AM		13		22		
D x thread depth D x 螺纹深度		G1/8" x 8 mm		G1/4" x 12 mm		
E		131		220		
F		100		180		
G		50		90		
L	L = 2 x A + Stroke 冲程					
M		36		51		
N x thread depth N x 螺纹深度		M4 x 7 mm		M6 x 10 mm		
S		33		51		
T x thread depth T x 螺纹深度		M4 x 9 mm		M6 x 12 mm		
U		42		63		
W		53		79		
Cushioning length 缓冲长度		18		34		

Example for order:
ZS+ Ø 25 Standard cylinder with broad yoke head
with stroke 100 mm

订单示例:
ZS+ Ø 25标准气缸, 带宽活塞杆头
冲程100 mm

Order number	订单编号
Port Standard	标准端口

1 2 5 1 - 0 0 0 0 - 0 1 0 0

Measurements table

测量值表

Piston-Ø 活塞-Ø	Ø 18 mm	Ø 25 mm	Ø 32 mm	Ø 40 mm	Ø 50 mm	Ø 63 mm
A		67,5		95		
AM		13		22		
D x thread depth D x 螺纹深度		G1/8" x 8 mm		G1/4" x 12 mm		
E		66		110		
F		35		70		
L	L = 2 x A + Stroke 冲程					
M		36		51		
N x thread depth N x 螺纹深度		M4 x 7 mm		M6 x 10 mm		
S		33		51		
T x thread depth T x 螺纹深度		M4 x 9 mm		M6 x 12 mm		
U		42		63		
W		53		79		
Cushioning length 缓冲长度		18		34		

Example for order:
ZK+ Ø 25 Standard cylinder short with broad yoke head
with stroke 100 mm

订单示例:
ZK+ Ø 25标准短缸, 带宽活塞杆头
冲程100 mm

Order number	订单编号
Port Standard	标准端口

2 2 5 1 - 0 0 0 0 - 0 1 0 0