

ZGS 夹紧缸

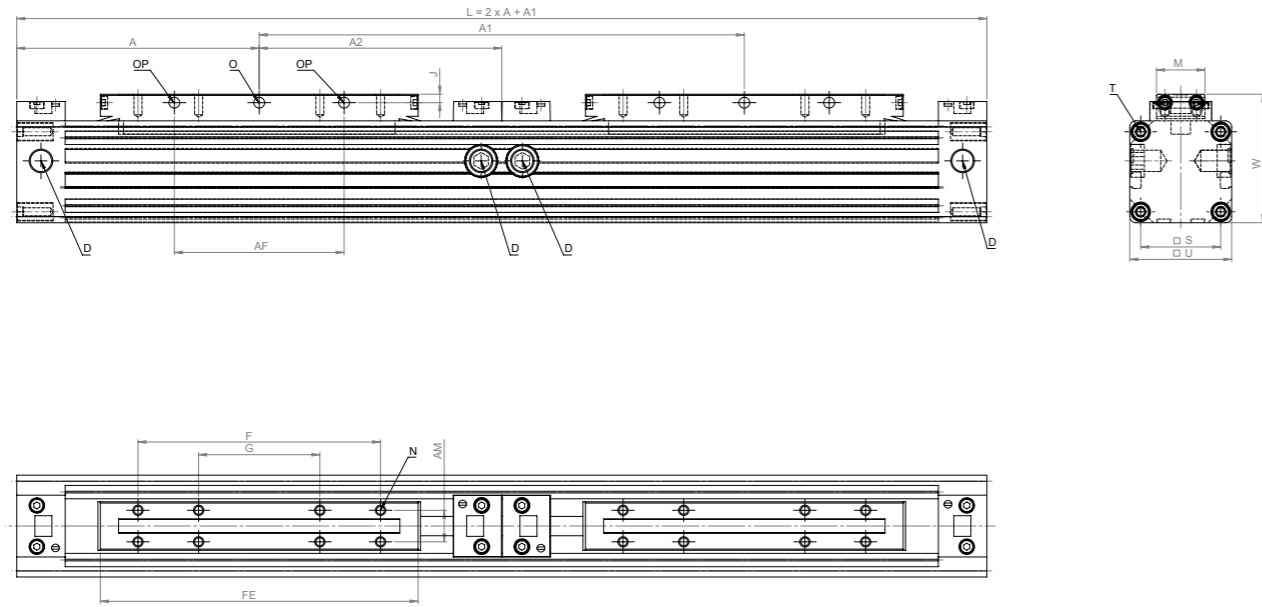

Measurements table

测量值表

Piston-Ø 活塞-Ø	Ø 18 mm	Ø 25 mm	Ø 32 mm	Ø 40 mm	Ø 50 mm	Ø 63 mm
A	80	100	120	150	180	215
A1 at least 最小A1	160	200	240	300	360	430
A2	A2 = A + Stroke 冲程					
AF	50	70	100	140	180	230
AM	10	13	16	22	29	40
D x thread depth D x 螺纹深度	M5 x 6 mm	G1/8" x 8 mm	G1/8" x 8 mm	G1/4" x 12 mm	G1/4" x 12 mm	G3/8" x 12 mm
E	103	131	171	220	280	333
F	75	100	140	180	220	280
G	---	50	70	90	110	140
J	3	3,5	4,5	5	6,5	8
L	L = 2 x A + A1					
M	15,5	20	25	33	42	54
N x thread depth N x 螺纹深度	M3 x 6 mm	M4 x 7 mm	M5 x 9 mm	M6 x 10 mm	M8 x 12 mm	M8 x 15 mm
Ø O	Ø 3,5	Ø 4,5	Ø 5,5	Ø 7	Ø 7	Ø 9
Ø OP	Ø 3,4	Ø 4,4	Ø 5,3	Ø 6,8	Ø 6,8	Ø 8,8
S	23,5	33	41	51	63	78
T x thread depth T x 螺纹深度	M3 x 7 mm	M4 x 9 mm	M5 x 10 mm	M6 x 12 mm	M8 x 12 mm	M8 x 12 mm
U	30	42	52	63	78	93
W	39	53	65	79	96	113,5
Cushioning length 缓冲长度	15	18	24	34	40	49

Example for order:
ZGS Ø 25 Gripping cylinder
distance A1 (open) 400 mm with stroke 100 mm

订单示例:
ZGS Ø 25 夹紧缸
距离A1 (开) 400, 冲程100 mm

Order number 订单编号

5	2	5	0	-	0	4	0	0	-	0	1	0	0
---	---	---	---	---	---	---	---	---	---	---	---	---	---



ZGK 夹紧短缸

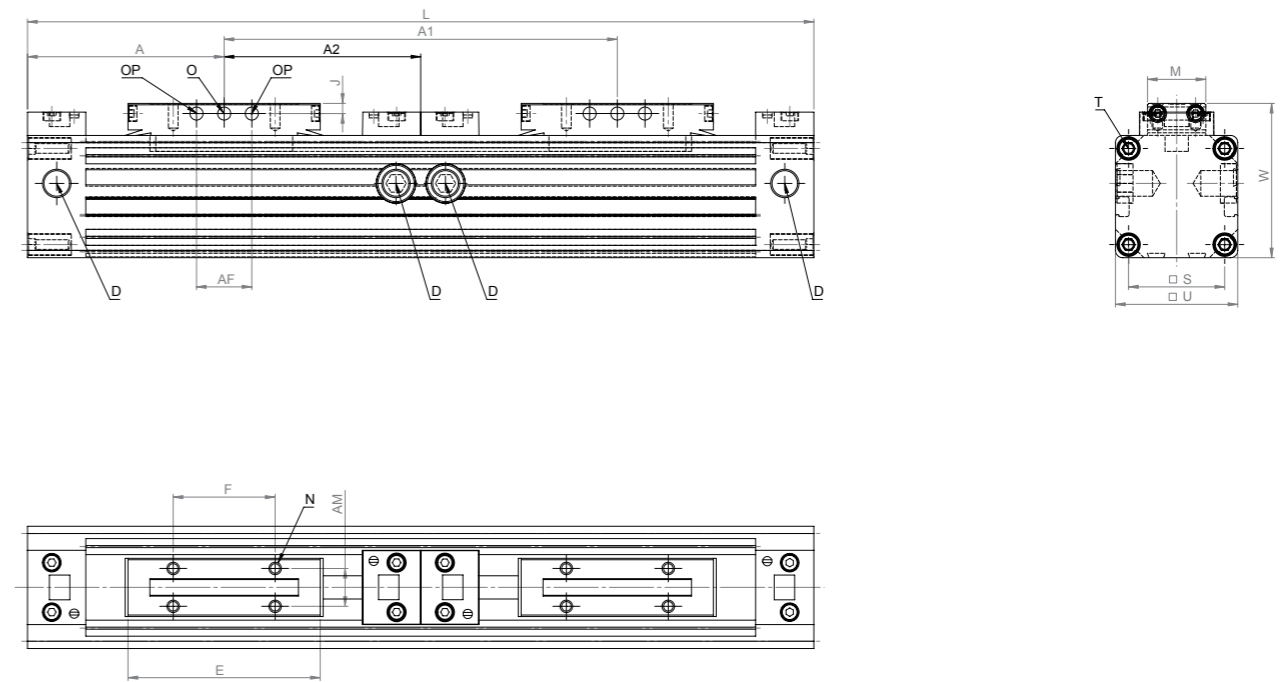

Measurements table

测量值表

Piston-Ø 活塞-Ø	Ø 18 mm	Ø 25 mm	Ø 32 mm	Ø 40 mm	Ø 50 mm	Ø 63 mm
A	57,5	67,5	77,5	95	105	125
A1 at least 最小A1	115	135	155	190	210	250
A2	A2 = A + Stroke 冲程					
AF	15	19	35	50	46	70
AM	10	13	16	22	29	40
D x thread depth D x 螺纹深度	M5 x 6 mm	G1/8" x 8 mm	G1/8" x 8 mm	G1/4" x 12 mm	G1/4" x 12 mm	G3/8" x 12 mm
E	58	66	86	110	130	153
F	30	35	55	70	70	100
J	3	3,5	4,5	5	6,5	8
L	L = 2 x A + A1 + Stroke 冲程					
M	15,5	20	25	33	42	54
N x thread depth N x 螺纹深度	M3 x 6 mm	M4 x 7 mm	M5 x 9 mm	M6 x 10 mm	M8 x 12 mm	M8 x 15 mm
Ø O	Ø 3,5	Ø 4,5	Ø 5,5	Ø 7	Ø 7	Ø 9
Ø OP	Ø 3,4	Ø 4,4	Ø 5,3	Ø 6,8	Ø 6,8	Ø 8,8
S	23,5	33	41	51	63	78
T x thread depth T x 螺纹深度	M3 x 7 mm	M4 x 9 mm	M5 x 10 mm	M6 x 12 mm	M8 x 12 mm	M8 x 12 mm
U	30	42	52	63	78	93
W	39	53	65	79	96	113,5
Cushioning length 缓冲长度	15	18	24	34	40	49

Example for order:
ZGS Ø 25 Gripping cylinder short
distance A1 (open) 400 mm with stroke 100 mm

订单示例:
ZGS Ø 25 夹紧短缸
距离A1 (开) 400, 冲程100 mm

Order number 订单编号

5	2	5	3	-	0	4	0	0	-	0	1	0	0
---	---	---	---	---	---	---	---	---	---	---	---	---	---