

20 – ZS+ Standard cylinder with broad yoke head

ZS+ Standardzylinder mit breitem Kraftbrückenkopf

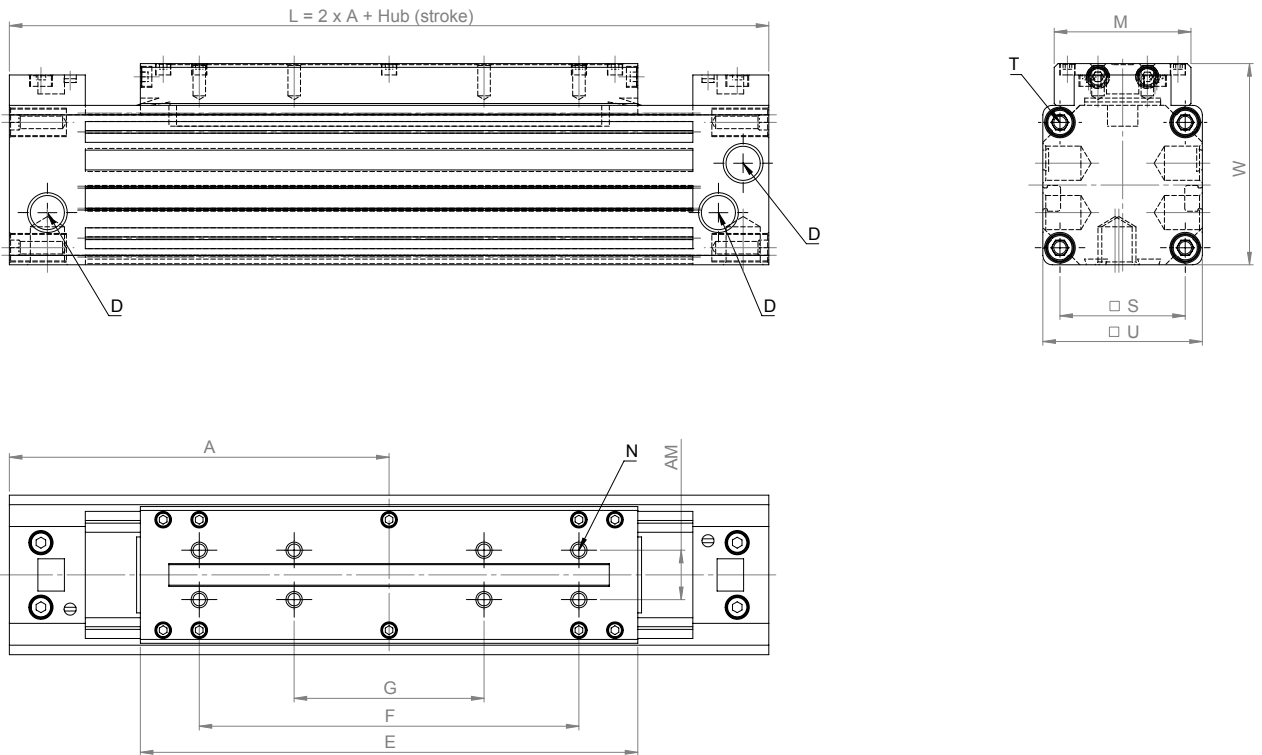

Measurements table

Maßtabelle

| Piston-Ø Kolben-Ø | Ø 18 mm | Ø 25 mm | Ø 32 mm | Ø 40 mm | Ø 50 mm | Ø 63 mm |
|-----------------------------------|------------------------|--------------|---------|---------------|---------|---------|
| A | | 100 | | 150 | | |
| AM | | 13 | | 22 | | |
| D x thread depth D x Gewindetiefe | | G1/8" x 8 mm | | G1/4" x 12 mm | | |
| E | | 131 | | 220 | | |
| F | | 100 | | 180 | | |
| G | | 50 | | 90 | | |
| L | L = 2 x A + Stroke Hub | | | | | |
| M | | 36 | | 51 | | |
| N x thread depth N x Gewindetiefe | | M4 x 7 mm | | M6 x 10 mm | | |
| S | | 33 | | 51 | | |
| T x thread depth T x Gewindetiefe | | M4 x 9 mm | | M6 x 12 mm | | |
| U | | 42 | | 63 | | |
| W | | 53 | | 79 | | |
| Cushioning length Dämpfungsweg | | 18 | | 34 | | |

Example for order:
ZS+ Ø 25 Standard cylinder with broad yoke head
with stroke 100 mm

Bestellbeispiel:
ZS+ Ø 25 Standardzylinder mit breitem Kraftbrückenkopf
mit Hub 100 mm

Order number

Bestellnummer

| | | | | | | | | | | | | | | | | |
|---------------|--------------------|---|---|---|---|---|---|---|---|---|---|---|---|---|---|---|
| Port Standard | Anschluss Standard | 1 | 2 | 5 | 1 | - | 0 | 0 | 0 | 0 | 0 | - | 0 | 1 | 0 | 0 |
|---------------|--------------------|---|---|---|---|---|---|---|---|---|---|---|---|---|---|---|